

THIS DRAWING IS UNPUBLISHED. RELEASED FOR PUBLICATION, 19 .  
 © COPYRIGHT 19 BY AMP INCORPORATED. ALL INTERNATIONAL RIGHTS RESERVED.

LOC	DIST	P	F	ZONE	LTR	DESCRIPTION	DATE	APPD
G	14				0	RELEASED PER PR 95-71	21AUG95	MJS

**METRIC**  
 DIMENSIONS LISTED IN mm [ INCHES ]

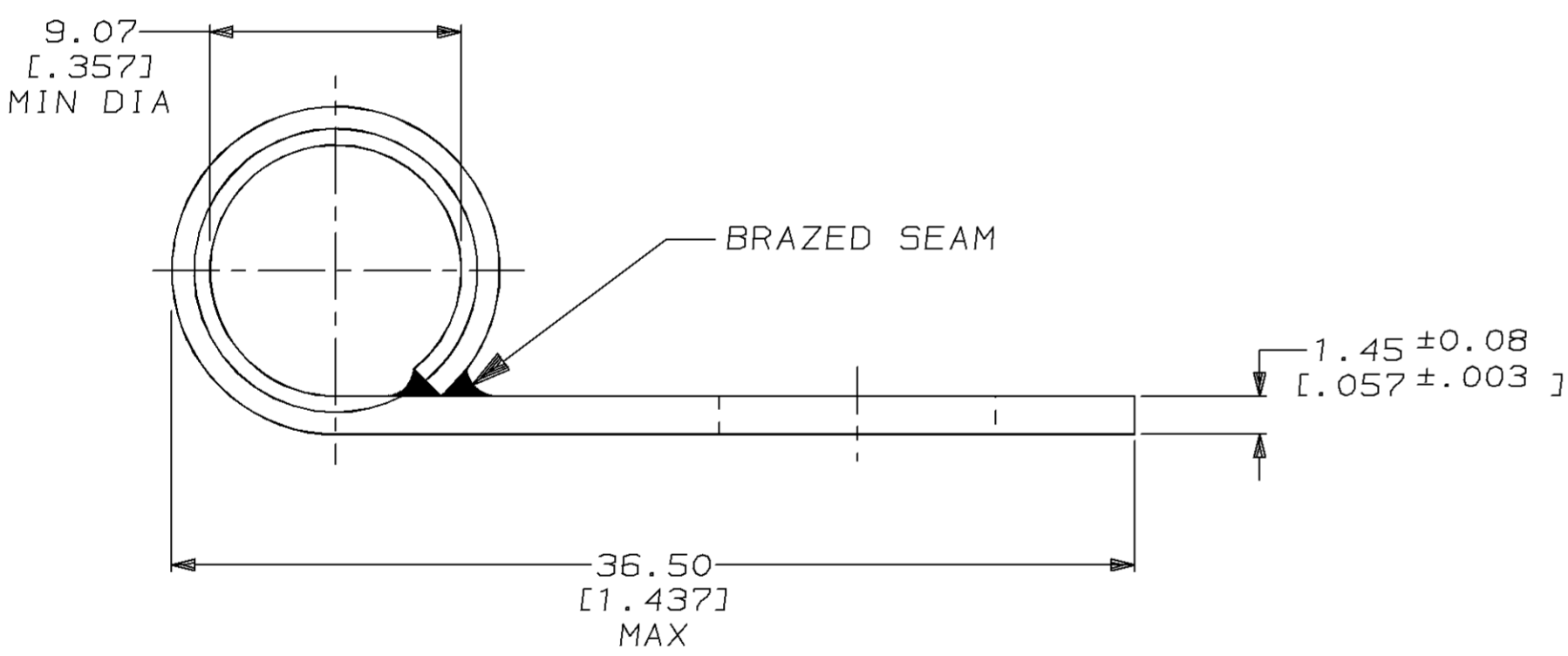
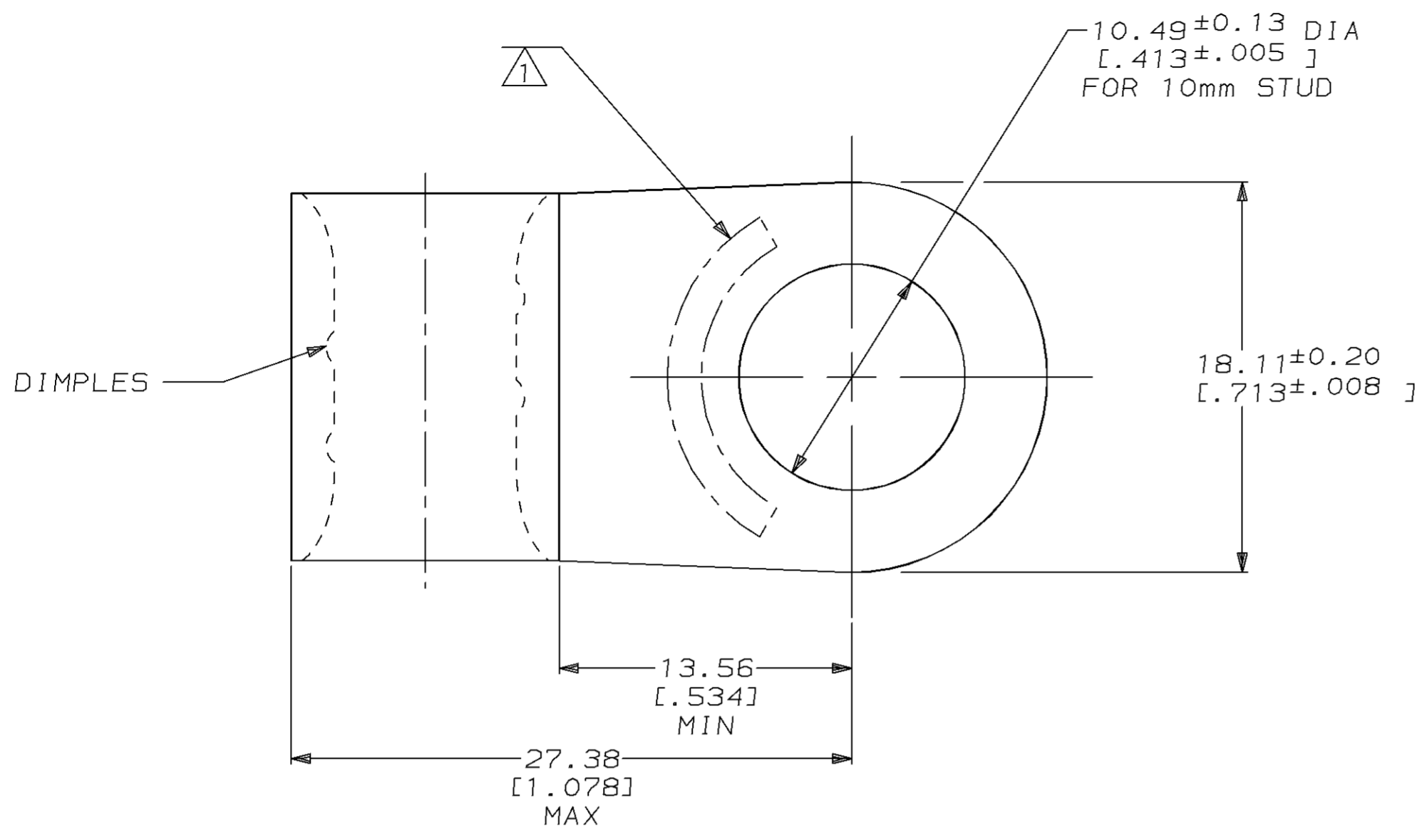

<b>AMP</b> WIRE RANGE	<b>UL</b> E13288 Listed
2 AWG SOLID OR STRANDED	PENDING
<b>SR</b> LR7189 Certified	MILITARY P/N AND CLASS
2 AWG SOLID OR STRANDED	NOT APPLICABLE

1 STAMP AMP 2W\* APPROX AS SHOWN

AMP INCORPORATED CUSTOMER SERVICE SYSTEMS		MAX RECOMMENDED OPERATING TEMPERATURE: 170°C MAX	DO NOT SCALE PRINT. UNLESS SPECIFIED DIMENSIONS IN mm [ INCHES ] TOLERANCES ON: 2 PLC DEC ± 0.20 [ .008 ] 3 PLC DEC ± - ANGLES ± -	DR 10AUG95 DK SCHRUM	<b>AMP</b> AMP Incorporated Harrisburg, PA 17105-3608		
FOR ADDITIONAL PRODUCT INFORMATION OR COPIES OF DRAWINGS AND TECHNICAL DOCUMENTS	PRODUCT INFORMATION CENTER 1-800-522-6752	VOLTAGE RATING: NOT APPLICABLE	MATERIAL COPPER PER ASTM B-152 ANNEALED	CHK 10AUG95 MJ SPICER	NAME TERMINAL, RING TONGUE, FLAG, SOLISTRAND™		
FOR APPLICATION TOOLING INFORMATION	TOOLING ASSISTANCE CENTER 1-800-722-1111	WIRE CROSS SECTIONAL AREA RANGE: 26.7-42.4mm² [ 52,600-83,700 ] CIR MILS SOLID OR STRANDED	FINISH TIN PLATE 0.00254 [ .000100 ] MIN THK PER MIL-T-10727	APPD 10AUG95 CH KULYNYCH	SIZE C	CAGE CODE 00779	DRAWING NO C=184147
FOR ORDER ENTRY	1-800-526-5142	THIS DRAWING IS A CONTROLLED DOCUMENT FOR AMP INCORPORATED. IT IS SUBJECT TO CHANGE AND THE CONTROLLING ENGINEERING ORGANIZATION SHOULD BE CONTACTED FOR THE LATEST REVISION.		APPD 10AUG95 JL MECKLEY	SCALE 4:1		SHEET 1 OF 1